

XE-W SERIES

ELECTRIC SELF-PROPELLED SCISSOR LIFT

Mantall[®]
AERIAL WORK PLATFORMS

Standard Features

- XE-W series working height is from 8m (about 26 feet) and 14m (about 46 feet).
- The platform can outreach 1m.
- XE-W series can be easily passed double standard door, large lift capacity, min. lift capacity is 350kg, max. lift capacity is 550kg.
- Proportional controls for lift and drive functions.
- Automatic 25 Amp battery charger provides strong power for vehicle.
- Safe distance protection when the platform lowering down. (CE)
- Manual Emergency platform lowering valve, when there is no power, the machine can be safely lowered down.
- Emergency stop at both platform and ground controls.
- Drive speed interlock limits speed while elevated.
- Multiple disc brakes provide smooth deceleration.
- When there is no power, manual brake release function can move the machines under the circumstances when there is no other forklift, lifting equipment and so on...
- Pothole guards protect the machine from tilting down when the machine moved on the raised position.
- Non-marking tires make sure there is no damage and no marks on the ground.
- AC wiring to platform
- Tilt level sensor with an audible alarm
- Beeper horn
- Hour meter
- Safety brackets
- Battery charge indicator
- Forklift pockets
- Diagnosis system
- Extended platform



美通让工作更轻松!

免费咨询电话: 4006178066

XE-W SERIES

Models	XE80W	XE100W	XE120W	XE140W	XE160W
Working height max (m)	8	10	12	14	16
Platform height max (m)	6	8	10	12	14
(2)Outreach (m)	1	1	1	1	1
Lifting capacity (kg)	550	450	350	350	230
Lifting capacity (kg) (Extended platform)	120	120	120	120	100
Weight (kg)ANSI/CSA Standard	1855	2040	2450	2690	3280
CE/AUS Standard	1975	2520	2950	3225	3400
Platform size(3) × (5) × (6)(L × W × H)m	2.3 × 1.15 × 1.1				
(4)The length of platform extended (m)	3.3	3.3	3.3	3.3	3.3
(7)Skirting board height (m)	0.172	0.172	0.172	0.172	0.176
Stowed size(8) × (9)(L × W)m	2.42 × 1.2				
(10)Stowed height (m)	2.12	2.25	2.38	2.50	2.64
(13)Length of the machine with platform extended (m)	3.5	3.5	3.5	3.5	3.5
(11)Height of the machine with platform folded (m)	1.56	1.69	1.82	1.95	2.08
Hydraulic tank capacity (L)	15	15	25	25	25
Gradeability	30%	30%	25%	23%	20%
(12)Wheelbase (m)	1.85				
Ground clearance (m)	0.1				
Pothole protection board ground clearance (m) (down)	0.019				
Inside rotation radius (m)	0				
Outside turning radius (m)	2.3				
Load number max	2				
Raised time/Lowering time (s)	32/30	39/31	58/37	72/45	80/58
Traction speed (km/h)	3.4				
Safe speed (km/h)	0.7				
Vertical tilt°	ANSI CSA		3		1.5
	CE/AUS		2		----
Lateral tilt°	ANSI CSA		2		1
	CE/AUS		1.5		----
Power source	4 × 6V; 225Ah				
Tire size (mm)	406 × 127 × 318				
Drive model	Hydraulic drive or electric drive				

Working Range

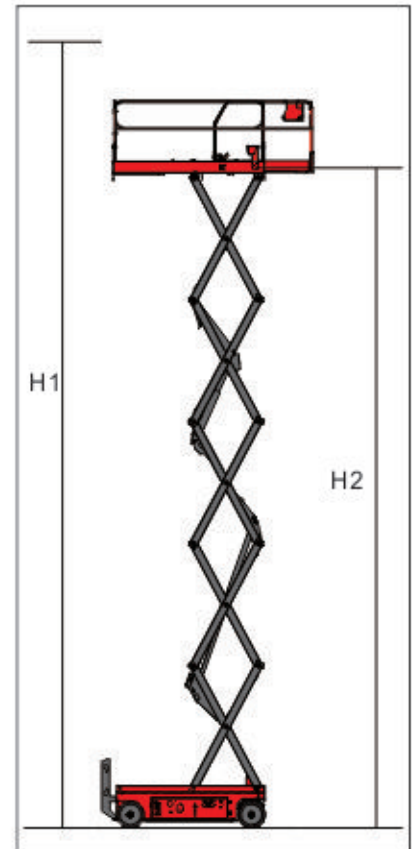

Collecting Chart

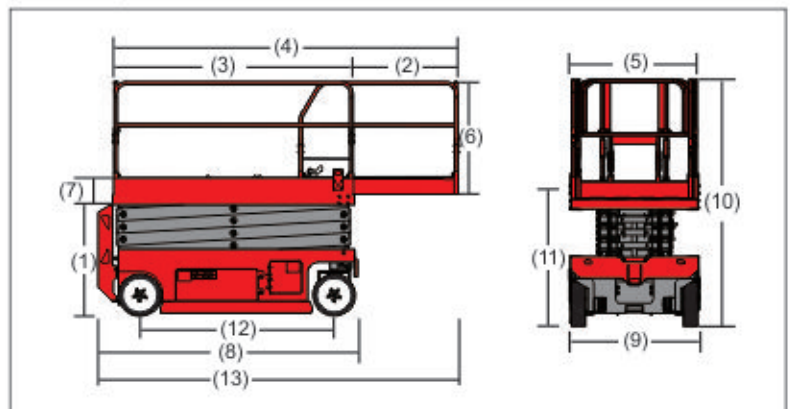

*The metric system height is 2 meters higher than platform height, the imperial height is 6 feet than platform height

**In the rising mode, the machine is designed to operate on a solid flat surface.

***Climbing ability is suitable for driving on the slope, the slope classification reference operation manual

****Weight according to the options and standards vary from country to country